



**Pali Design, Inc.**

1525 Hymus Boul.  
 Dorval, QC  
 H9P-1 J5 Canada  
 Phone: 1-514-421-0309

customerservice@pali-design.com

www.pali-design.com

# Assembly Instructions

## Tuscan Hutch

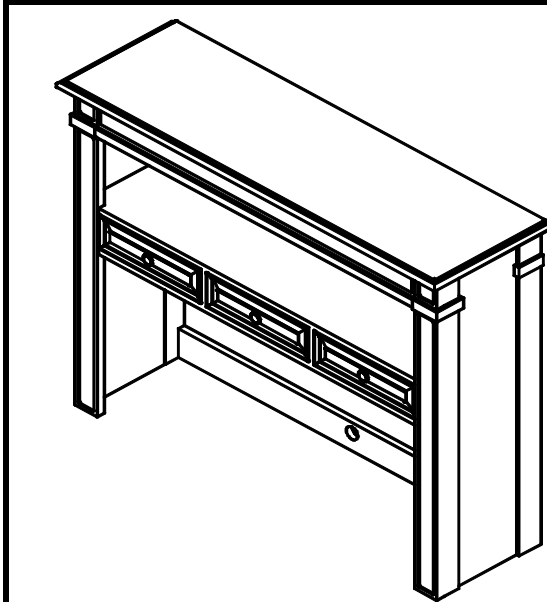

This Hutch has been designed for your child's comfort and your convenience. Quality material and workmanship have gone into this Hutch which will provide a stable and efficient Hutch for your baby if properly assembled and maintained. For the security of your child and your own peace of mind be sure to follow the assembly instructions exactly. Adult assembly is required. A periodic check should be made of all bolts and screws, which should be tightened if needed. Moisture and heat are harmful to the finish; for this reason use extreme caution when vaporizer is in use. The vapor steam should always be aimed away from the Hutch as well as away from other wood furniture. Some types of soft plastic toys could damage the finish when placed against it.

### Hardware List:

<b>A</b> KD Screw (30 mm) 8x 	<b>B</b> KD Screw (40 mm) 4x 	<b>C</b> Cam Lock Bolt 4x 
<b>D</b> Cam Lock Nut 4x 	<b>E</b> Washer 4x 	<b>F</b> Spring Washer 12x 
<b>G</b> Back Panel Screw (16 mm) 28x 	<b>H</b> Screw attach to Double Dresser (16 mm) 2x 	<b>I</b> Allen Key 1x 
<b>J</b> Knob 3x 	<b>R</b> Knob 3x 	<b>S</b> Knob's Screw (25 mm) 3x 

Tools Needed for Assembly: 	<b>INSTRUCTION LEAFLET</b>	<i>Important, keep for future reference. Read carefully.</i>	<b>Adult assembly is required.</b>
--------------------------------	----------------------------	--	------------------------------------

Hutch Parts List:				<b>IMPORTANT:</b> In order to properly assemble the furniture, carry out the operations in the order specified. Failure to assemble the furniture in the manner recommended could make the furniture hazardous. Carefully remove and lay out all parts. Familiarize yourself with all diagrams to facilitate the assembly of your furniture. Check parts enclosed in hardware bag with the HARDWARE PARTS LIST to be sure all are included and quantities are correct.
1x	Top (J)	1x	Upper Front Support (N)	
2x	Side Panel (K1+K2)	1x	Upper Back Support (O)	
1x	Drawer Frame Assembly (L)	1x	Lower Back Support (P)	
3x	Drawer (M)	2x	Back Panel (Q)	

**Hutch** Step **1**

# Assembling Hutch

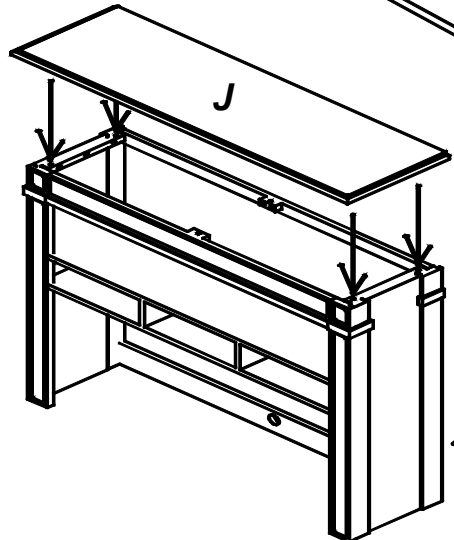
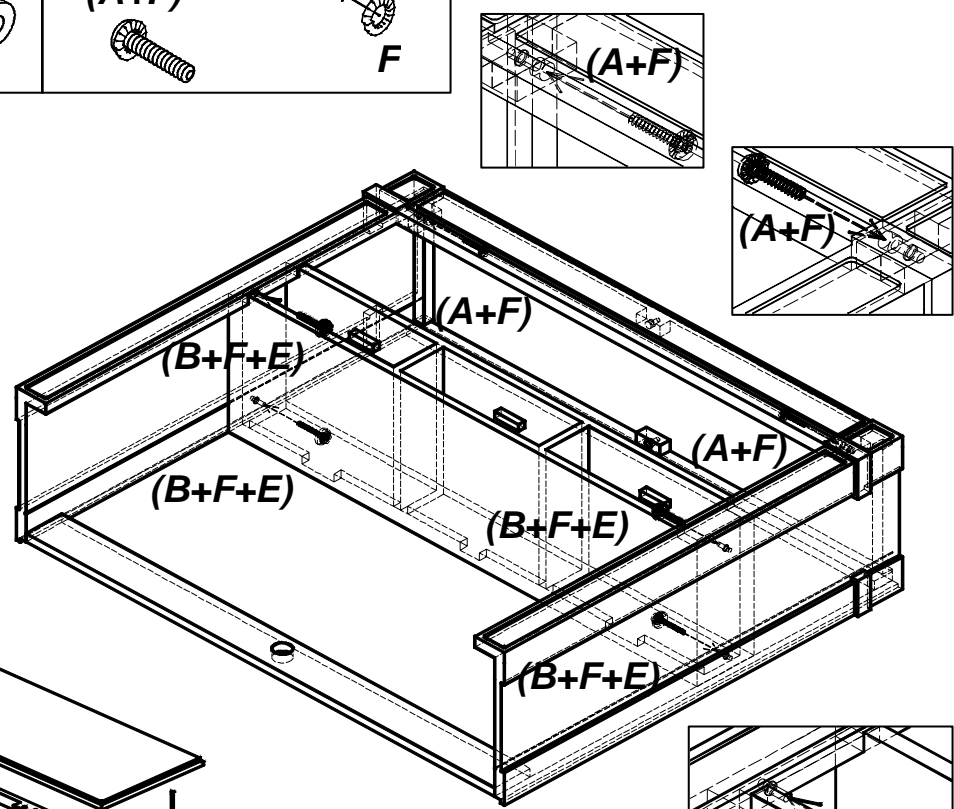
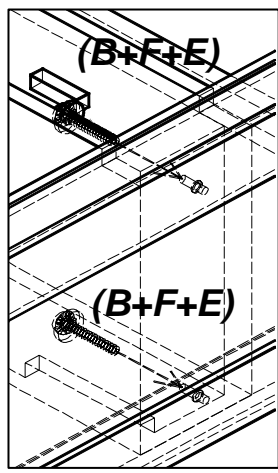
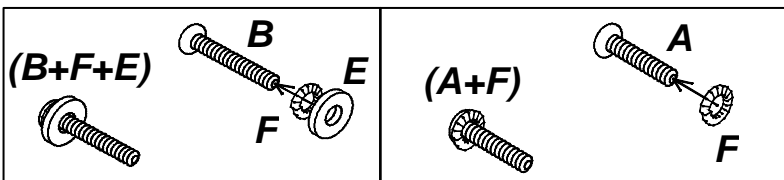
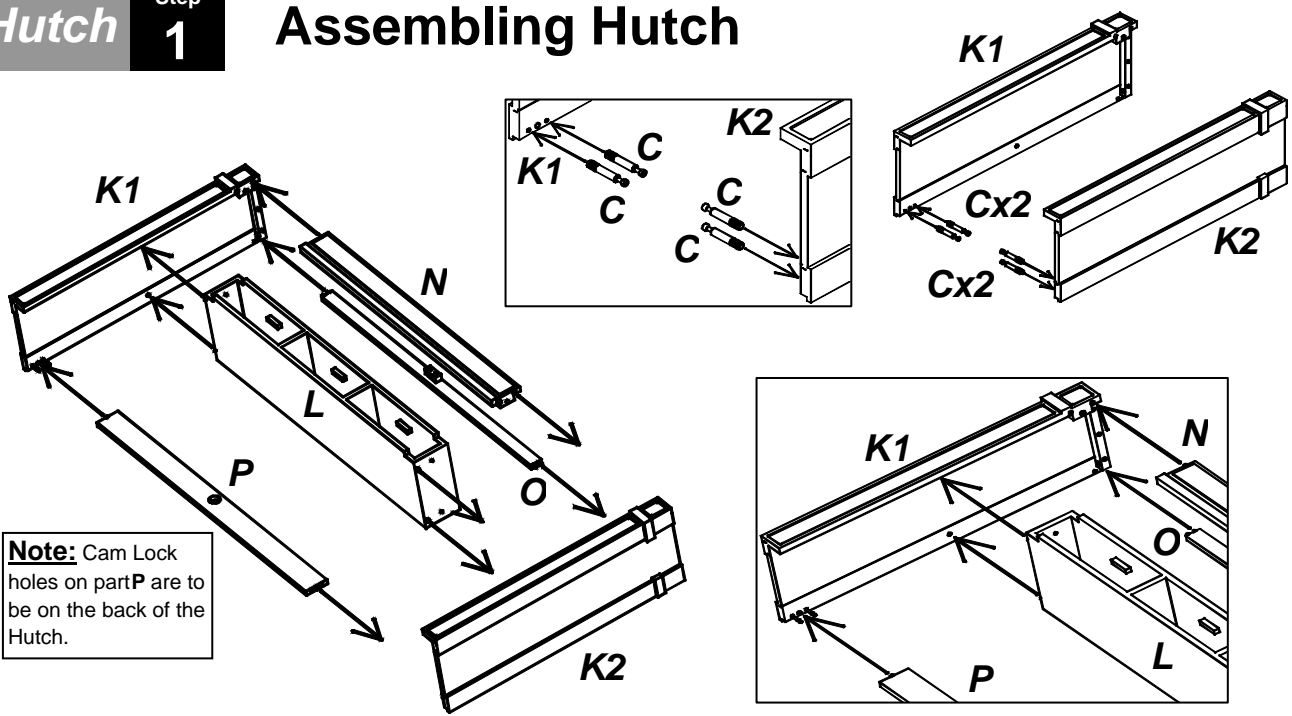

**Note:** Flip the Hutch to it's upright position before attaching Top (J).

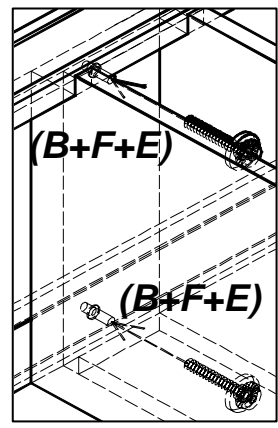

# Hutch

## Step 2

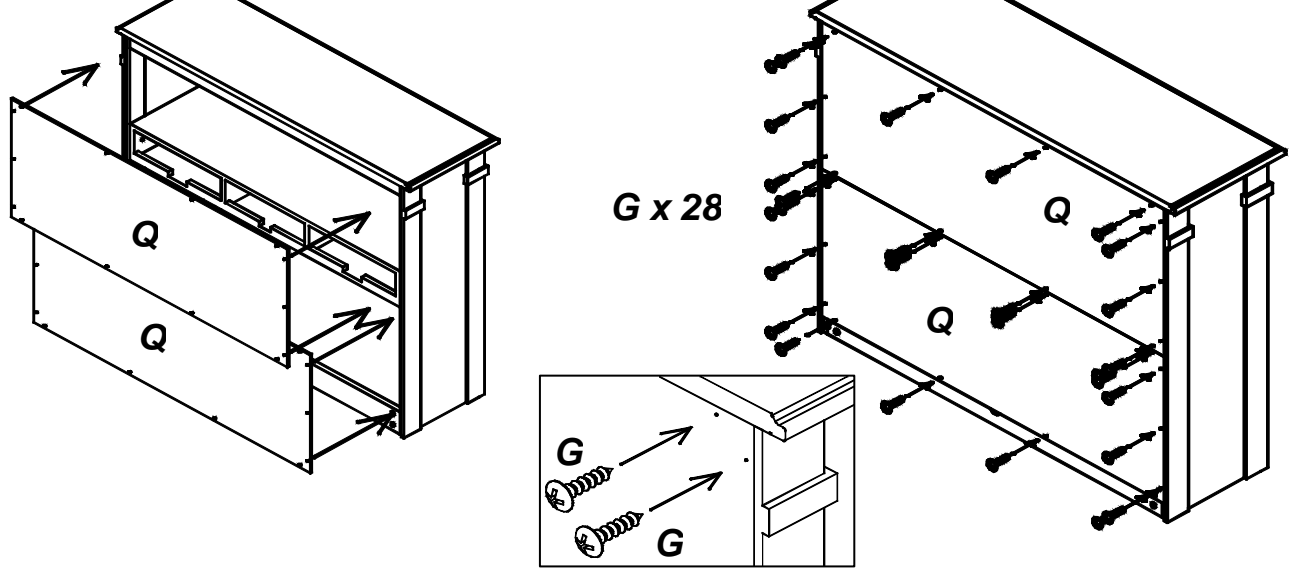
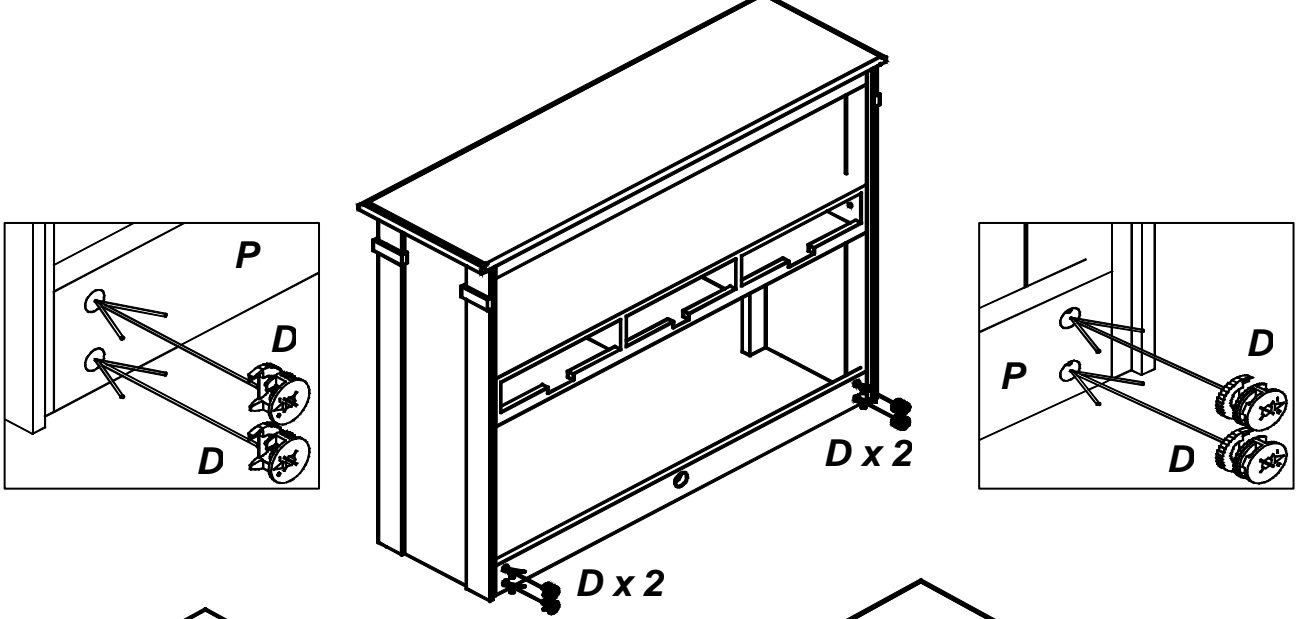
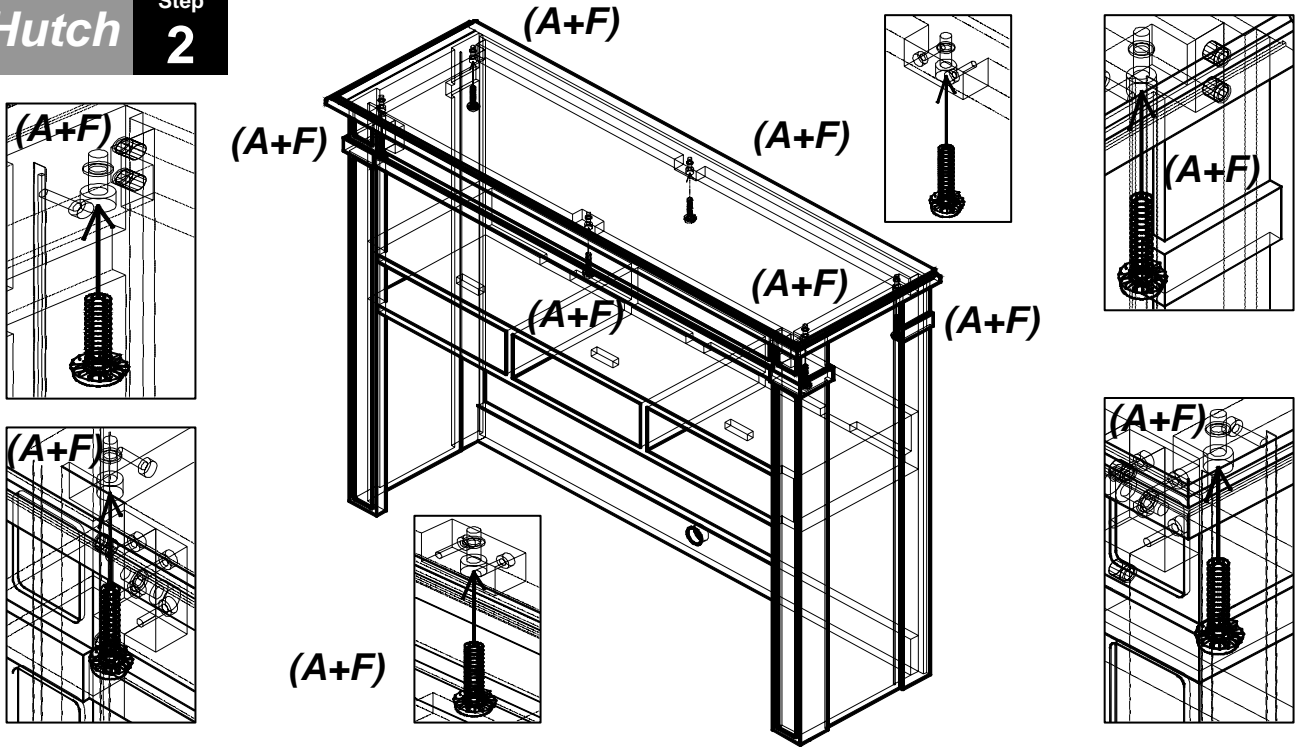

**Hutch** Step **3**

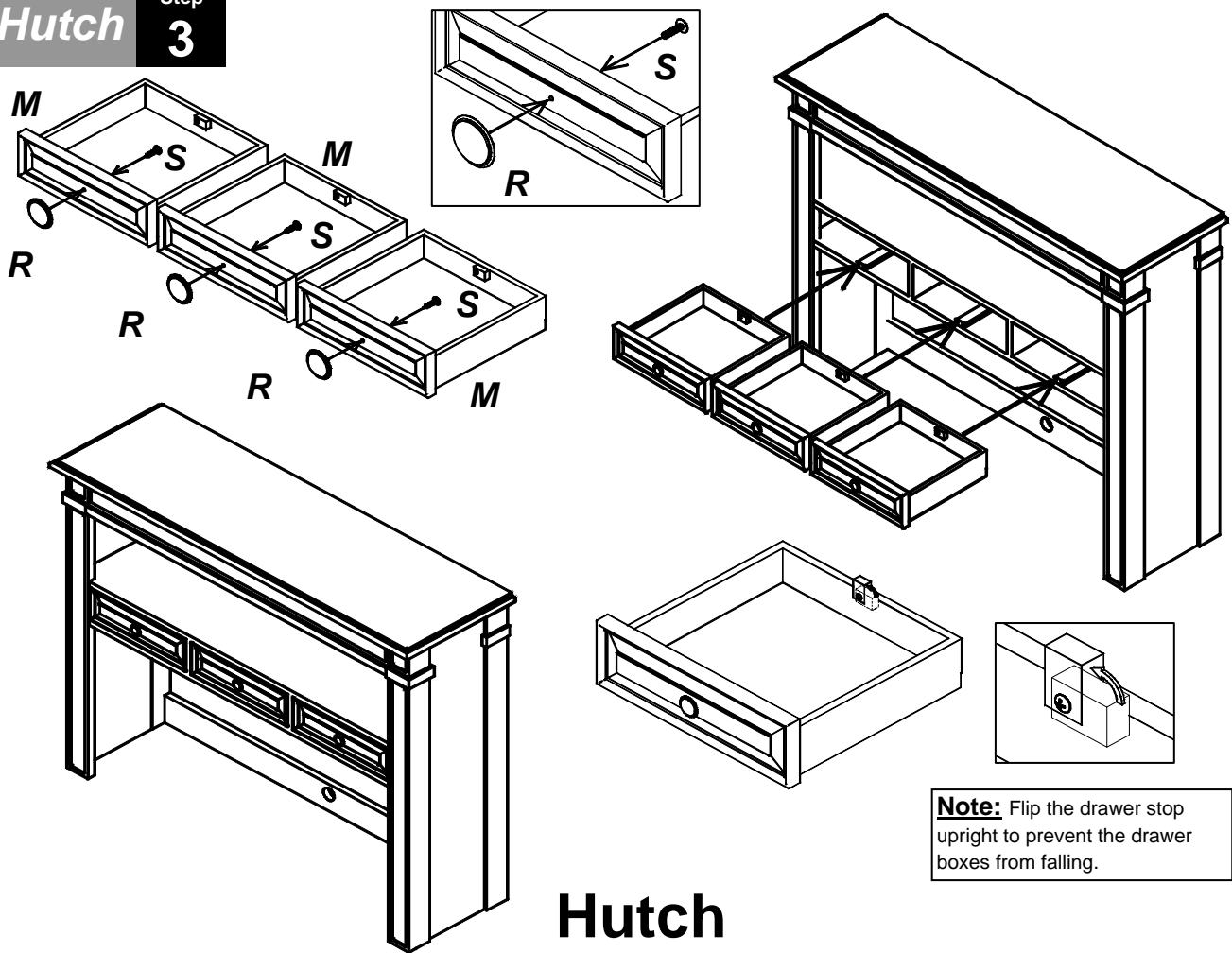

**Hutch**

**Hutch** Step **4**

**Attaching Hutch on Double Dresser**

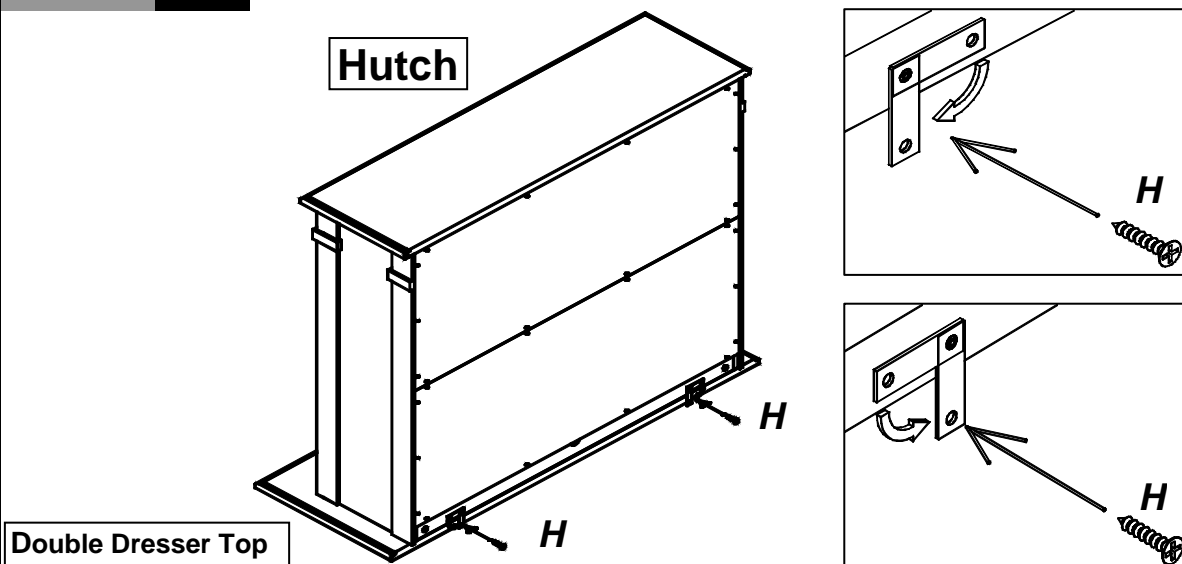

**CARE AND MAINTENANCE**



When cleaning your furniture, please use a non-toxic, non-abrasive cleaner. Mix a solution of water with a small amount of mild dishwashing liquid. Apply to furniture surface with a soft, damp cloth lightly dampened in solution. After cleaning, dry completely with a soft, dry cloth.